



## Company Culture

**G** + Great  
**M** + Workmanship  
**I** + Idea  
**P** + Personalise  
**P** + Popularize  
**O** + Objective

GWIPPO

## Vitreous and porcelain enamels

PRODUCT MANUAL | Glass-Lined Equipment Parts

30-year experience in enamel making & craftsmanship inheritance >>>

JIANGYIN GWIPPO ENAMEL CORP.,LTD

Address : No. 8 YiShan Rd, Yumen Industrial Park, ShengGang, JiangYin City, JiangSu Province

Email : zj@gwippo.com.ky@gwippo.com.info@gwippo.com

Contact : 18921192958,13621535272

Website : www.gwippo.com



JIANGYIN GWIPPO ENAMEL CORP.,LTD



**Keep improving,  
casting quality model.**

---

# CONTENT

---

---

## | About Us **01-08**

---

Company Profile	02
Company Developmental Milestones	03
Enterprise Honors	07

---

## | Vitreous And Porcelain Enamels **09-29**

---

Laboratory Equipment And Team	10
Manufacturing Process And Quality Control	11
Product Introduction	12
Introduction Of Porcelain Enamel Varieties	27
Enamel And Enameling Process Combined	27

---

## | Glass Lining Products **30-38**

---

Glass Lined Pipe	10
Double-sided Enamel Feeding Tube	11
Glass Lined Porous Disc Condenser	12
Glass Lined Tower Section Tower Cap	27
Glass Lined Equipment Products	27

---

## | Gwippo Business Scope **39**

---

## ABOUT US

· 1995  
Founded in



## GWIPPO

30-year experience in enamel making & craftsmanship inheritance

Keep improving & be a model of quality goods



## COMPANY PROFILE

### JIANGYIN GWIPPO ENAMEL CORP., LTD.

Founded in 1995, Jiangyin GWIPPO Enamel Corp., Ltd. has participated in drafting 8 national standards and 6 industrial standards of vitreous and porcelain enamels. The company has received 5 patents for invention and have been granted more than 30 patents for utility models. Specializing in the research and development of enamel technologies, we have grown into a high and new technology enterprise integrating R&D, production, sales, and service.

GWIPPO has an advanced automated glaze material production line with an annual capacity of over 10,000 tons, provides services for about 90% of glass lined equipment manufacturers in China, and establishes partnerships with other countries and regions including South East Asia and Korea. We keep improving, hoping to be the model of quality goods in this section. We stay dedicated to the R&D, pilot production and production of high-end vitreous and porcelain enamels and glass lining products.

GWIPPO has a professional after-sales service team. With 30 years of experience in enameling skills and 26 years of experience in enamel making, we are proficient in the operation processes of enamels and dedicated to providing high-quality after-sales service. Customer satisfaction is our unremitting pursuit.

GWIPPO wins the market with integrity and earns customer trust with dedication. Through joint efforts with our customers at home and abroad, we are able to make great achievements together.

Listed in 2017, stock name: GWIPPO, stock code: 871274

## ▶▶▶ THE DEVELOPMENT COURSE

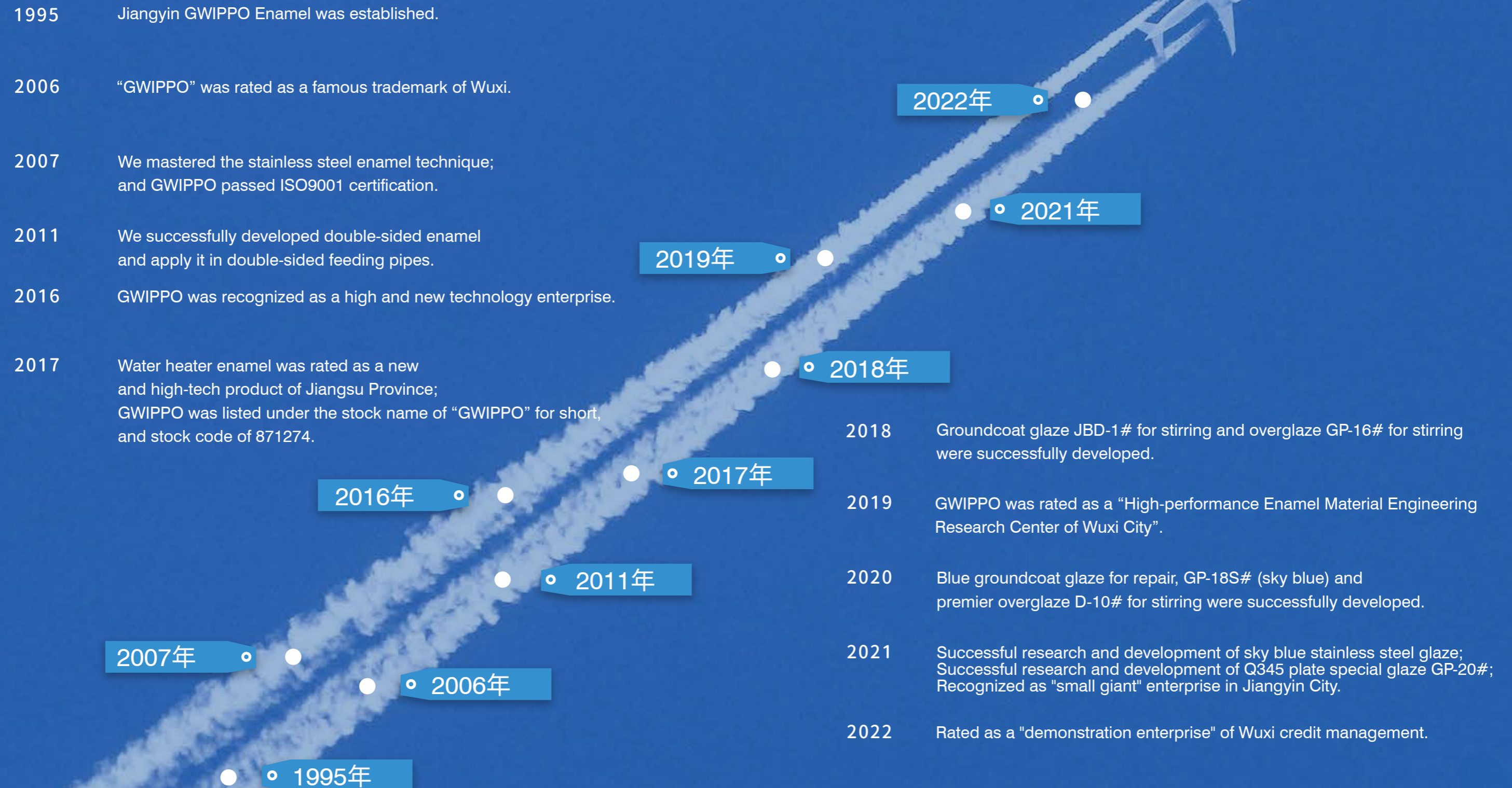

## GB National Standards drafted by GWIPPO

No.	Standard Name	Standard Type	Standard No.	How to participate
1	Vitreous and porcelain enamels-Determination of resistance to chemical corrosion by boiling acids and their vapours	National standard	GB/T 7989-2013	Mainly drafted by Gwippo
2	Vitreous and porcelain enamels-Determination of resistance to alkaline liquids	National standard	GB/T 7988-2013	Mainly drafted by Gwippo
3	Specification of glass-lined equipment for industry	National standard	GB 25025-2010	Mainly drafted by Gwippo
4	Determination of coefficient of mean linear thermal expansion for vitreous and porcelain enamels	National standard	GB/T 7991.7-2019	Mainly drafted by Gwippo
5	Vitreous and porcelain enamels-Determination of resistance to therm shock	National standard	GB/T 7987-2003	Mainly drafted by Gwippo
6	Vitreous and porcelain enamels-Determination of resistance to hot sodium hydroxide	National standard	GB/T 7988-2002	Mainly drafted by Gwippo
7	Glass lining - Test methods - Part 4: Determination of resistance to mechanical impact	National standard	GB/T 7991.4-2019	Mainly drafted by Gwippo
8	Vitreous and porcelain enamels-Determination of resistance to condensing hydrochloric acid vapour	National standard	GB/T 7989-2003	Mainly drafted by Gwippo

## NB/HG Industrial standards drafted by GWIPPO

No.	Standard Name	Standard Type	Standard No.	How to participate
1	Vitreous and porcelain enamels	Industry standard	HG/T 4798-2021	First drafting unit by Gwippo
2	Vitreous and porcelain enamels for sheet steel-Production of specimens for testing	Industry standard	HG/T 3105-2009	Exclusively drafted by Gwippo
3	Vitreous and porcelain enamels-Determination of fluidity behavior-fusion flow test	Industry standard	HG/T 2735-2009	Mainly drafted by Gwippo
4	Standard test methods for sieve analysis of porcelain enamels	Industry standard	HG/T 3128-2009	Mainly drafted by Gwippo
5	Vitreous and porcelain enamels-Determination of resistance to abrasion	Industry standard	HG/T 3221-2009	Mainly drafted by Gwippo
6	Enamel parts of heat storage water heater	Industry standard	QB/T 2590-2021	First drafting unit by Gwippo

▶▶ ENTERPRISE HONOR



Patents for invention

ISO 9001 Quality Management System Certification



Patens for utility models

5

Patents For  
Invention

20

Patents for  
utility models

8

National standards  
of glass lining  
products

6

Drafting 6  
industrial standards



Certificates of new and high technology enterprise and high-tech new products



## 2 THE GLASS LINING GLAZE

>> Experimental Testing Equipment And Team

>> Production Process And Quality Control

>> Product Introduction

· Vitreous And Porcelain Groundcoat Enamels

· Vitreous And Porcelain Overglaze Enamels

>> Introduction Of High-end Glaze Materials

>> Enamel And Enameling Process Combined

### ▶▶▶ Experimental Testing Equipment And Team

GWIPPO has a solid technical foundation and a powerful R&D team. Under the technical leadership of Xianzhong XU, the former Chairman of the Board, GWIPPO has established its High-performance Enamel Research Institute. Subordinate to it, our “Glass Enamel Postgraduate Workstation of Donghua University” is equipped with an advanced physical and chemical laboratory and an enamel baking laboratory. We have established strict criteria of glaze material formulation. Many senior consultants of enamels participate in relevant R&D activities and discussions.

**Material Test Laboratory** ▶ Test component content, fineness, viscosity, and whiteness of raw materials.

**Enamel Baking Laboratory 1** ▶ Perform Fusion flow test, glaze property tests (e.g., adsorbing capacity, fineness, bulk density, and slump), test plate enamel firing and conductivity testing.

**Enamel Baking Laboratory 2** ▶ Perform Fusion flow test, glaze property tests (e.g., adsorbing capacity, fineness, bulk density, and slump), test plate enamel firing and conductivity testing.

**Physical And Chemical Property Testing Laboratory** ▶ Uniformity, adherence, acid resistance, alkali resistance, abrupt temperature difference change resistance, mechanical shock resistance, boiling water erosion resistance, the mean of coefficients of thermal expansion thermal expansivity, sintering test, and solubility tests of mixed materials.



## ▶▶▶ Productionprocess And Quality Control

## ▶▶▶ Product Introduction

### Production Process

### Product Overview

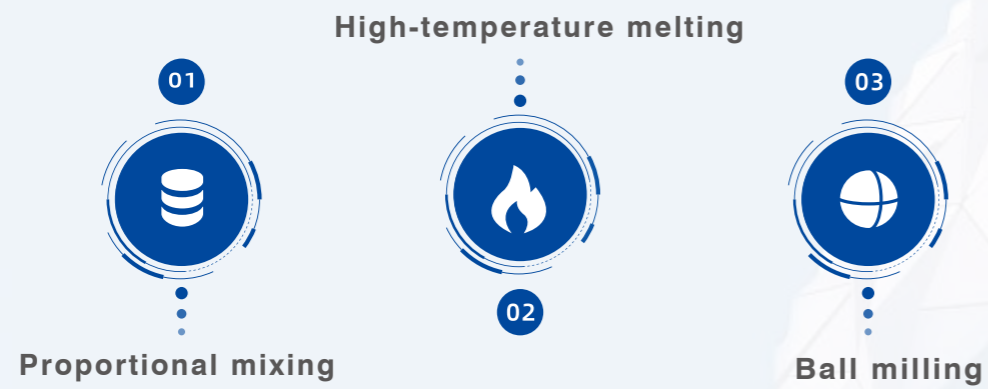

### Quality Control

We have stable workers with rick experience in production. Centering on prevention, we can timely identify and solve quality issues, thus lowering their frequency and preventing defective products from leaving factory.

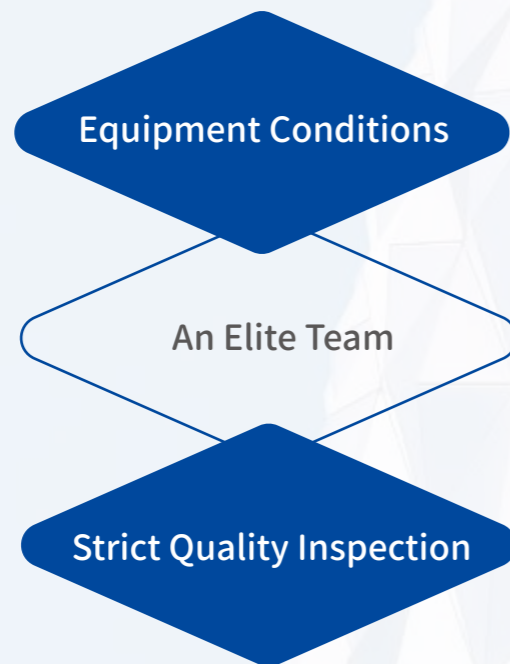

GWIPPO has built a production base of 18,000m2, and is equipped with an automated production line integrating R&D, design, and manufacturing.

By standardizing the quality control system, raw materials, semi-finished products, and finished products are all tested, ensuring rigorous control over all links.

Over-glaze For Stirring	JT-7#	JT-9901H#		
Acid resistant glaze	JT-7#	JT-9901H#	JT-4#	
Acid and alkali resistant glaze	JT-7#	JT-9901H#	JT-4#	GP-2#
	JT-9902#	GP-12# (Powder)	GP-10# (Powder)	
Featured glaze (sky blue)	TL-4#	GP-18S#		
	JTD-1#	JTD-Y# (Stainless steel groundcoat glaze)	JBD-1#	Groundcoat glaze for repair # (Dark gray)
High-end ground-coat glaze		Featured ground-coat glaze		Groundcoat glaze for repair # (blue)

## Classification Of Vitreous And Porcelain Enamels

Groundcoat glaze (10 varieties)	
01	JTD-1#G High temperature groundcoat glaze powder
02	JTD-1#S Moderate temperature groundcoat glaze powder
03	JTD-1# Groundcoat glaze powder
04	JBD-1# Groundcoat glaze powder for stirring
05	1#C Groundcoat glaze slurry
06	1#C(Anti-fish-scaling) Anti-fish-scaling groundcoat glaze slurry
07	E03# Low temperature groundcoat glaze slurry
08	Groundcoat glaze for repair (dark grey) General groundcoat glaze powder/slurry for repair
09	Groundcoat glaze for repair (cobalt blue) Groundcoat glaze powder/slurry in cobalt blue
10	JTD-Y# Stainless steel groundcoat glaze

  

Overglaze (20 varieties)	
01	Acid resistant glaze JT-5809#、JT-0587#、JT-02-8#、JT-02-9#
02	General acid and alkali resistant glaze JT-7#、JT-9901H#、JT-4#
03	High-quality acid and alkali resistant glaze GP-2#、JT-9902#、GP-7#
04	Super-grade acid and alkali resistant glaze GP-12#、GP-10#
05	High-quality overglaze for stirring GP-16#
06	Super overglaze for stirring D-10#
07	Featured glaze (sky blue) GP-18S#、TL-4#

## Groundcoat Glaze



### Gwippo Vitreous And Porcelain Groundcoat Enamel Advantage

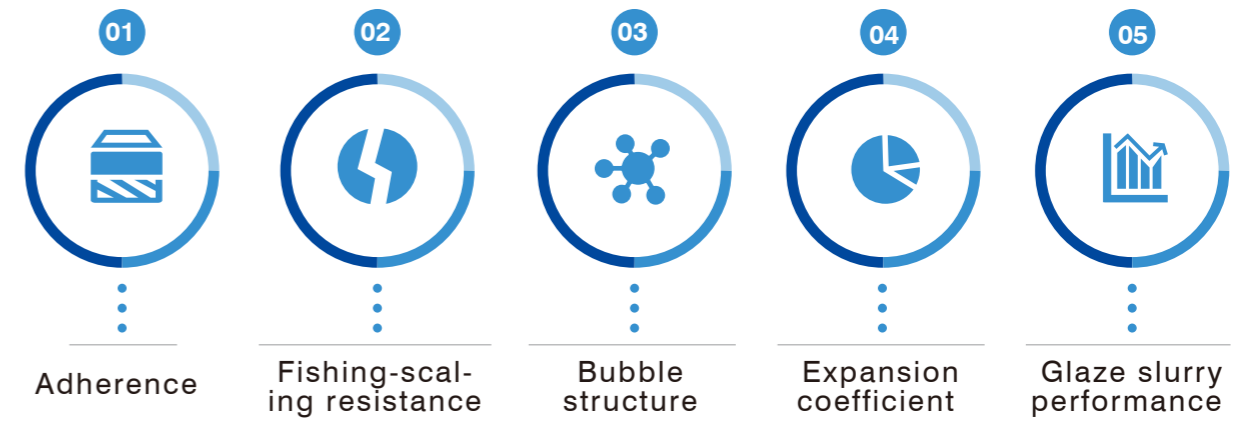

01 High adhesiveness is proved by a 90° bending test of the steel plate;

02 permeability of the groundcoat glaze layer is enhanced by introducing oxides that produce fine pores;

03 a bubble structure reasonably and uniformly distributed;

04 the expansion coefficient matches the steel plate;

05 Grinding of the imported clay improves rheological properties (e.g., suspendability and pausibility) of the glaze slurry, generating more outstanding maneuverability.

**OVERGLAZE**

**Super Grade Overglaze Series**

- High temperature resistance
- Fish-scaling resistance
- High corrosion resistance
- Extending the service life of devices

**Super-grade acid and alkali-resistant glaze GP-10#**

**01 GP-10#**

In general cases of high temperature, GP-10 shows excellent performance of resistance to acids.

EXCELLENT ACID RESISTANCE

EXCELLENT ALKALI RESISTANCE

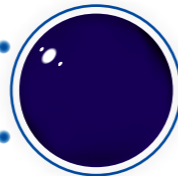

**ACID CORROSION RESISTANCE**

Concerning all acid substances in the chemical industry, hydrochloric acids are rather common and their corrosion to devices is comparatively stronger. When the concentration of hydrochloric acids reaches 10%, their acid corrosion capability is the highest. In this case, enamels have the weakest corrosion resistance. Then, the corrosion resistance of the enamel becomes increasingly strong when the acid concentration keeps rising from 10%. Moreover, the corrosion rate diagram of hydrochloric acids is also applicable to hydrobromic acids, iodic acids and chloroacetic acids.

When sulfuric acids, sulfurous acids, nitric acids, or nitrous acids are selected as the media, the acid corrosiveness reaches its maximum when their concentration is around 20% and corrosion resistance of enamels accordingly declines. Once their concentration exceeds 20%, the corrosion resistance of enamel is improved as the concentration keeps increasing.

Phosphoric acid, however, is an exception. In a phosphoric acid solution, corrosion resistance drops as the acid concentration goes up. Here, what calls for special attention is that phosphoric acid commonly contains fluorine as an impurity. For example, the maximum operating temperature is suggested to be no higher than 120°C when the acid concentration is 70%; and if the operating temperature reaches 140°C, the concentration of the phosphoric acid should be no higher than 30%.

GP-10 is applicable to strong acid media at any concentration provided that the operating temperature is no higher than 120°C, such as hydrochloric acids, sulfuric acids, sulfurous acids, hydrobromic acids, hydroiodic acids, chloroacetic acids, nitric acids, and nitrous acids. Exceptionally, the concentration should be no greater than 70% at the operating temperature of 120°C as far as phosphoric acids are concerned. If the operating temperature exceeds 120°C, please refer to the corrosion rate diagram for specifics.

**ALKALI CORROSION RESISTANCE**

Alkali corrosion resistance of vitreous and porcelain enamels declines as the temperature rises. When the concentration of a strong alkaline medium reaches 50% or its pH value is 14, the corresponding reaction temperature needs to be below 50°C. If its PH value is 13, the operating temperature should be no higher than 80°C. Thermokalite must be used with caution and strict control over temperature for a reason that corrosiveness to vitreous and porcelain enamels will be doubled when the temperature increases by 10°C. If you need to put alkali in a vessel, please select a draft tube to prevent the alkali from flowing along the high-temperature wall of this vessel. Moreover, GP-10 is applicable to strong alkaline media at a concentration of 50% or having a PH value of 14; and the corresponding operating temperature should be below 50°C. If its PH value is 13, the operating temperature should be lower than 80°C.

**STEAM CORROSION RESISTANCE**

The thermal shock resistance of vitreous and porcelain enamels is closely related to shrinkage stress on its surface. The higher the shrinkage stress is, the stronger the thermal shock will be. Therefore, the allowable temperature difference between rapid heating and fast cooling depends on the temperature of the tank wall.

**THEMAL SHOCK RESISTANCE**

All enamels for vitreous and porcelain enamels have high corrosion resistance in the condition of being below the boiling point of water. When vapor phase corrosion occurs in a condition of being above this boiling point, glaze materials with superior alkali resistance should be selected.

**FLUORIDE**

Fluorides can corrode silicon structures. Therefore, they should be avoided to the greatest extent even though their dosage is considerably low. Moreover, the corrosion mechanism of fluorides is also very complicated.

Fluorides corrode glass lined layers via an acid medium, the hydrofluoric acid at an ionic state. Once they contact dry hydrofluoric acid gas, the corrosiveness of fluorides or fluorine mixtures (in alkaline media) and anhydrous organic solvents to vitreous and porcelain enamels can be comparatively weak.

Erosion by fluorides makes glass lined layers not glossy any longer in most cases, which further leads to the production of pinholes in the glass lined layer. Although there exist great variations in corrosion rates of hydrofluoric acids to the glass lined layer, the corrosion can be more significant when the concentration exceeds 10PPM.

**ISOETCH CURVE**

Isoetch curves below are plotted based on the performance of GP-10 and stand for the correspondence between medium concentrations and temperature values when the corrosion rates are 0.1mm and 0.2mm per year respectively. When the corrosion rate is below 0.1mm per year, it has no impact on vitreous enamels; if the corrosion rate lies between 0.1mm per year and 0.2mm per year, close attention should be paid to the degree that the glass lined layer is corroded; and when it is above 0.2mm per year, vitreous enamels are not recommended.

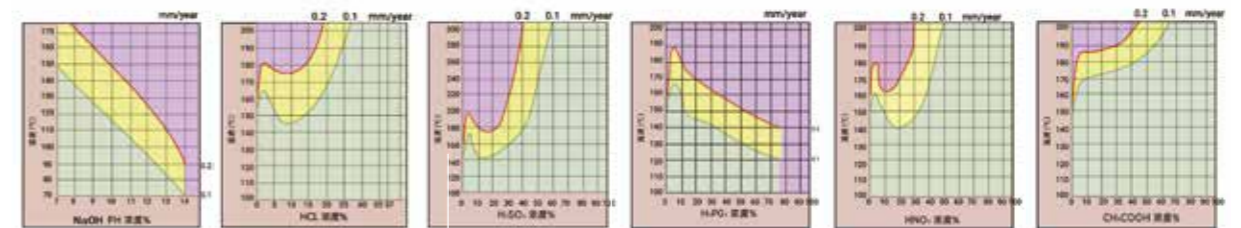

Technical indicators	Measuring units	Testing standards	Reference targets	Testing data
				GP-10#
168-hour corrosion resistance to 20% boiling hydrochloric acids	g/m <sup>2</sup> .d	GB/T7989-2013	≤1.2	0.2-0.3
24-hour corrosion resistance to 0.1mol/L 80°C sodium hydroxides	g/m <sup>2</sup> .d	GB/T7988-2013	≤5.0	1.0-1.5
Resistance to abrupt temperature difference variations	°C	GB/T7987-2013	≥200	203-210
Mechanical shock resistance	J	GB/T7991.4-2019	≥220x10 <sup>-3</sup>	270-290
	Color			Cobalt blue
Applicable to				Reactors & stirring accessories

## SUPER GRADE OVERGLAZE SERIES

High temperature resistance Fish-scaling resistance High corrosion resistance Extending the service life of devices

### Super-grade acid and alkali-resistant glaze GP-12#

#### 02 GP-12#

EXCELLENT ACID RESISTANCE

HIGH TEMPERATURE STABILITY

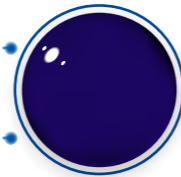

### ACID CORROSION RESISTANCE

In general cases of high temperature, GP-12 shows excellent performance of resistance to acids. Concerning all acid substances in the chemical industry, hydrochloric acids are rather common and their corrosion to devices is comparatively stronger. When the concentration of hydrochloric acids reaches 10%, their acid corrosion capability is the highest. In this case, enamels have the weakest corrosion resistance. Then, the corrosion resistance of enamel becomes increasingly strong when the acid concentration keeps rising from 10%. Moreover, the corrosion rate diagram of hydrochloric acids is also applicable to hydrobromic acids, iodic acids and chloroacetic acids.

When sulfuric acids, sulfurous acids, nitric acids, or nitrous acids are selected as the media, the acid corrosiveness reaches its maximum when their concentration is around 20% and corrosion resistance of enamel accordingly declines. Once their concentration exceeds 20%, the corrosion resistance of enamel is improved as the concentration keeps increasing.

Phosphoric acid, however, is an exception. In a phosphoric acid solution, corrosion resistance drops as the acid concentration goes up. Here, what calls for special attention is that phosphoric acid commonly contains fluorine as an impurity. For example, the maximum operating temperature is suggested to be no higher than 110°C when the acid concentration is 70%; and if the operating temperature reaches 140°C, the concentration of the phosphoric acid should be no higher than 30%.

GP-12 is applicable to strong acid media at any concentration provided that the operating temperature is no higher than 120°C, such as hydrochloric acids, sulfuric acids, sulfurous acids, hydrobromic acids, hydroiodic acids, chloroacetic acids, nitric acids, and nitrous acids. Exceptionally, the concentration should be no greater than 70% at the operating temperature of 120°C as far as phosphoric acids are concerned. If the operating temperature exceeds 120°C, please refer to the corrosion rate diagram for specifics.

### ALKALI CORROSION RESISTANCE

Alkali corrosion resistance of vitreous and porcelain enamels declines as the temperature rises. Thermokalkite must be used with caution and strict control over temperature for a reason that corrosiveness to vitreous and porcelain enamels can be doubled when the temperature increases by 10°C. If you need to put alkali in a vessel, please select a draft tube to prevent the alkali from flowing along the high-temperature wall of this vessel. Moreover, GP-12 is applicable to strong alkaline media having a PH value below 13. If its PH value is 13, the operating temperature should be lower than 60°C.

### STEAM CORROSION RESISTANCE

All vitreous and porcelain enamels have high corrosion resistance in the condition of being below the boiling point of water. When vapor phase corrosion occurs in a condition of being above this boiling point, glaze materials with superior alkali resistance should be selected.

### THERMAL SHOCK RESISTANCE

The thermal shock resistance of vitreous and porcelain enamels is closely related to shrinkage stress on its surface. The higher the shrinkage stress is, the stronger the thermal shock will be. Therefore, the allowable temperature difference between rapid heating and fast cooling depends on the temperature of the tank wall.

### FLUORIDE

Fluorides can corrode silicon structures. Therefore, they should be avoided to the greatest extent even though their dosage is considerably low. Moreover, the corrosion mechanism of fluorides is also very complicated.

Fluorides corrode glass lined layers via an acid medium, the hydrofluoric acid at an ionic state. Once they come contact hydrofluoric acid gas, the corrosiveness of fluorides or fluorine mixtures (in alkaline media) and anhydrous organic solvents to vitreous and porcelain enamels can be comparatively weak.

Erosion by fluorides makes glass lined layers not glossy any longer in most cases, which further leads to the production of pinholes in the layers. Although there exist great variations in corrosion rates of hydrofluoric acids to the glass lined layer, the corrosion can be more significant when the concentration exceeds 10PPM.

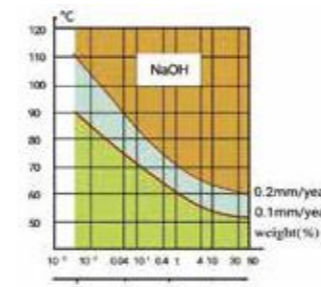

Corrosion resistance to NaOH

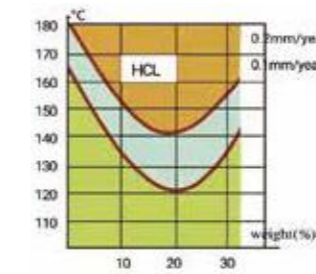

Corrosion resistance to HCL

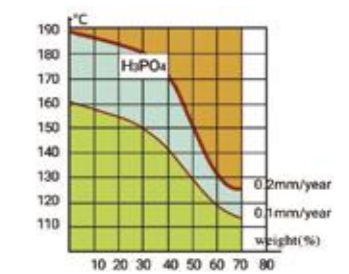

Corrosion resistance to H<sub>3</sub>PO<sub>4</sub>

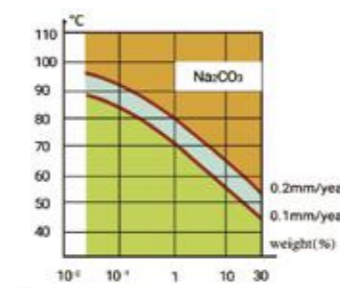

Corrosion resistance to Na<sub>2</sub>CO<sub>3</sub>

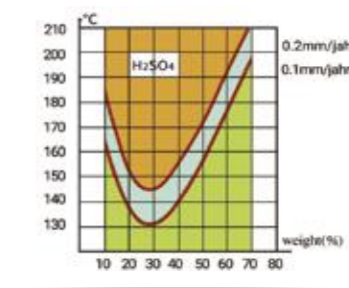

Corrosion resistance to H<sub>2</sub>SO<sub>4</sub>

Technical indicators	Measuring units	Testing standards	Reference targets	Testing data
				GP-12#
168-hour corrosion resistance to 20% boiling hydrochloric acids	g/m <sup>2</sup> .d	GB/T7989-2013	≤1.2	0.2-0.3
24-hour corrosion resistance to 0.1mol/L 80°C sodium hydroxides	g/m <sup>2</sup> .d	GB/T7991.1-2021	≤5.0	1.5-2.0
Resistance to abrupt temperature difference variations	°C	GB/T7987-2013	≥200	210-250
Mechanical shock resistance	J	GB/T7991.4-2019	≥220x10 <sup>-3</sup>	280-330
Color				Cobalt blue
Applicable to				Reactors

## Super Grade Overglaze Series

 High temperature resistance  Fish-scaling resistance  High corrosion resistance  Extending the service life of devices

### Super grade glaze for stirring D-10#

#### 01 D-10#



### ACID CORROSION RESISTANCE

D-10 is a high-end porcelain enamels specially designed for stirring developed by GWIPPO. In elegant cobalt blue, it has excellent chemical and physical properties of alkali and acid resistance. Thanks to a high coefficient of expansion, it is rather suitable for stirring accessories. In general cases of high temperature, D-10 still shows superior acid corrosion resistance. Concerning all acid substances in the chemical industry, hydrochloric acids are rather common and their corrosion to devices is comparatively stronger. When the concentration of hydrochloric acids reaches 10%, their acid corrosion capability is the highest. In this case, enamels have the weakest corrosion resistance. Then, the corrosion resistance of the enamel becomes increasingly strong when the acid concentration keeps rising from 10%. Moreover, the corrosion rate diagram of hydrochloric acids is also applicable to hydrobromic acids, hydroiodic acids and chloroacetic acids.

When sulfuric acids, sulfurous acids, nitric acids, or nitrous acids are selected as the media, the acid corrosiveness reaches its maximum when their concentration is around 20% and corrosion resistance of enamels accordingly declines. Once their concentration exceeds 20%, the corrosion resistance of enamel is improved as the concentration keeps increasing.

Phosphoric acid, however, is an exception. In a phosphoric acid solution, corrosion resistance drops as the acid concentration goes up. Here, what calls for special attention is that phosphoric acid commonly contains fluorine as an impurity. For example, the maximum operating temperature is suggested to be no higher than 120°C when the acid concentration is 70%; and if the operating temperature reaches 150°C, the concentration of the phosphoric acid should be no higher than 30%.

D-10 is applicable to strong acid media at any concentration provided that the operating temperature is no higher than 120°C, such as hydrochloric acids, sulfuric acids, sulfurous acids, hydrobromic acids, hydroiodic acids, chloroacetic acids, nitric acids, and nitrous acids. Exceptionally, the concentration should be no greater than 70% at the operating temperature of 120°C as far as phosphoric acids are concerned. If the operating temperature exceeds 120°C, please refer to the corrosion rate diagram for specifics.

### ALKALI CORROSION RESISTANCE

Alkali corrosion resistance of vitreous and porcelain enamels declines as the temperature rises. When the concentration of a strong alkaline medium reaches 50% or its pH value is 14, the corresponding reaction temperature should be lower than 50°C. If its PH value is 13, the operating temperature should be no higher than 80°C. Thermokalite must be used with caution and strict control over temperature for a reason that corrosiveness to vitreous and porcelain enamels can be doubled when the temperature increases by 10°C. If you need to put alkali in a vessel, please select a draft tube to prevent the alkali from flowing along the high-temperature wall of this vessel. Moreover, GP-10 is applicable to strong alkaline media at a concentration of 50% or having a PH value of 14; and the corresponding operating temperature should be lower than 50°C. If its PH value is 13, the operating temperature should be lower than 80°C.

### STEAM CORROSION RESISTANCE

All vitreous and porcelain enamels have high corrosion resistance in the condition of being below the boiling point of water. When vapor phase corrosion occurs in a condition of being above this boiling point, enamels with superior alkali resistance should be selected.

### THERMAL SHOCK RESISTANCE

The thermal shock resistance of vitreous and porcelain enamels is closely related to shrinkage stress on its surface. The higher the shrinkage stress is, the stronger the thermal shock will be. Therefore, the allowable temperature difference between rapid heating and fast cooling depends on the temperature of the tank wall.

### FLUORIDE

Fluorides can corrode silicon structures. Therefore, they should be avoided to the greatest extent even though their dosage is considerably low. Moreover, the corrosion mechanism of fluorides is also very complicated.

Fluorides corrode glass lined layers via an acid medium, the hydrofluoric acid at an ionic state. Once they contact dry hydrofluoric acid gas, the corrosiveness of fluorides or fluorine mixtures (in alkaline media) and anhydrous organic solvents to vitreous and porcelain enamels can be comparatively weak.

Erosion by fluorides makes glass lined layers not glossy any longer in most cases, which further leads to the production of pinholes in glass lined layers. Great variations in glass lined layer corrosion rates of hydrofluoric acids can be more significant when the concentration exceeds 10PPM.

Technical indicators	Measuring units	Testing standards	Reference targets	Testing data
				D-10#
168-hour corrosion resistance to 20% boiling hydrochloric acids	g/m <sup>2</sup> .d	GB/T7989-2013	≤1.2	0.2-0.25
24-hour corrosion resistance to 0.1mol/L 80°C sodium hydroxides	g/m <sup>2</sup> .d	GB/T7988-2013	≤5.0	1.0-1.3
Resistance to abrupt temperature difference variations	°C	GB/T7987-2013	≥200	200-203
Mechanical shock resistance	J	GB/T7991.4-2019	≥220x10 <sup>-3</sup>	240-280

Color

Cobalt blue

Applicable to

Reactors & stirring accessories

## High-end Overglaze Series



Extension of service life

### Acid and alkali resistant GP-2#

### Acid and alkali resistant T-9902#

#### 01 GP-2#



#### 02 JT-9902#



Technical indicators	Measuring units	Testing standards	Reference targets	Testing data
				GP-2#
168-hour corrosion resistance to 20% boiling hydrochloric acids	g/m <sup>2</sup> .d	GB/T7989-2013	≤1.2	0.4-0.5
24-hour corrosion resistance to 0.1mol/L 80°C sodium hydroxides	g/m <sup>2</sup> .d	GB/T7991.1-2021	≤5.0	2.0-2.6
Resistance to abrupt temperature difference variations	°C	GB/T7987-2013	≥200	200-210
Mechanical shock resistance	J	GB/T7991.4-2019	≥220x10 <sup>-3</sup>	240-280

Color

Cobalt blue

Applicable to

Reactors & stirring accessories

Technical indicators	Measuring units	Testing standards	Reference targets	Testing data
				GP-2#
168-hour corrosion resistance to 20% boiling hydrochloric acids	g/m <sup>2</sup> .d	GB/T7989-2013	≤1.2	0.4-0.45
24-hour corrosion resistance to 0.1mol/L 80°C sodium hydroxides	g/m <sup>2</sup> .d	GB/T7991.1-2021	≤5.0	1.8-2.3
Resistance to abrupt temperature difference variations	°C	GB/T7987-2013	≥200	200-210
Mechanical shock resistance	J	GB/T7991.4-2019	≥220x10 <sup>-3</sup>	240-280

Color

Cobalt blue

Applicable to

Reactors & stirring accessories

## High-end Overglaze Series ⌵

🕒 Extension of service life

### ▶ High-quality glaze for stirring: GP-16#

#### 🕒 01 GP-16#

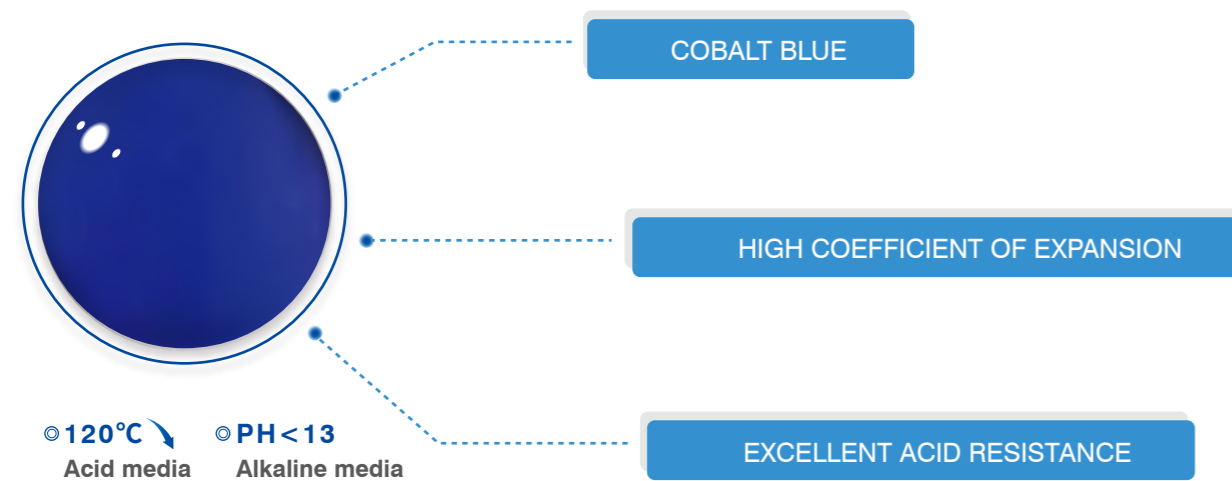

Technical indicators	Measuring units	Testing standards	Reference targets	Testing data GP-16#
168-hour corrosion resistance to 20% boiling hydrochloric acids	g/m <sup>2</sup> .d	GB/T7989-2013	≤1.2	0.4-0.5
24-hour corrosion resistance to 0.1mol/L 80°C sodium hydroxides	g/m <sup>2</sup> .d	GB/T7991.1-2021	≤5.0	2.0-2.5
Resistance to abrupt t emperature difference variations	°C	GB/T7987-2013	≥200	200-203
Mechanical shock resistance	J	GB/T7991.4-2019	≥220x10 <sup>-3</sup>	220-260
Color		Cobalt blue		
Applicable to		stirring accessories		

### ▶ High-quality glaze for stirring: GP-18S#

#### 🕒 02 GP-18S#



Technical indicators	Measuring units	Testing standards	Reference targets	Testing data GP-2#
168-hour corrosion resistance to 20% boiling hydrochloric acids	g/m <sup>2</sup> .d	GB/T7989-2013	≤1.2	0.25-0.30
24-hour corrosion resistance to 0.1mol/L 80°C sodium hydroxides	g/m <sup>2</sup> .d	GB/T7991.1-2021	≤5.0	1.8-2.0
Resistance to abrupt t emperature difference variations	°C	GB/T7987-2013	≥200	200-210
Mechanical shock resistance	J	GB/T7991.4-2019	≥220x10 <sup>-3</sup>	240-280
Color		Cobalt blue		
Applicable to		Reactors & stirring accessories		

# GWIPPO

## General Overglaze Series



Super-high cost performance

Satisfy 80~90% market demands

### Acid resistant JT-5809#, JT-02-8# & JT-02-9#



The use of general acid-resistant glaze is merely limited to acid conditions. They are inapplicable to high-temperature (>100°C) and hydrolysis reactions, or alkaline media.

#### 01 JT-5809#

Technical indicators	Measuring units	Testing standards	Reference targets	Testing data
				JT-5809#
168-hour corrosion resistance to 20% boiling hydrochloric acids	g/m <sup>2</sup> .d	GB/T7989-2013	≤0.5	0.4-0.5
24-hour corrosion resistance to 0.1mol/L 80°C sodium hydroxides	g/m <sup>2</sup> .d	GB/T7991.1-2021	≤8.0	7.0-8.0
Resistance to abrupt temperature difference variations	°C	GB/T7987-2013	≥180	210-240
Mechanical shock resistance	J	GB/T7991.4-2019	≥220x10 <sup>-3</sup>	280-320
Color	Blue			
Applicable to	Reactors			

#### 02 JT-02-8#、JT-02-9#

Technical indicators	Measuring units	Testing standards	Reference targets	Testing data
				JT-02-8#
168-hour corrosion resistance to 20% boiling hydrochloric acids	g/m <sup>2</sup> .d	GB/T7989-2013	≤0.5	0.45-0.5
24-hour corrosion resistance to 0.1mol/L 80°C sodium hydroxides	g/m <sup>2</sup> .d	GB/T7991.1-2021	≤8.0	7.0-8.0
Resistance to abrupt temperature difference variations	°C	GB/T7987-2013	≥180	200-203
Mechanical shock resistance	J	GB/T7991.4-2019	≥220x10 <sup>-3</sup>	230-250
Color	Blue			
Applicable to	Reactors & stirring accessories			

### Acid and Alkali resistant JT-7#, JT-9901# & JT-4#



Different reaction temperatures, pressures, temperature rise/drop rates and materials required, pose different requirements to glass-lined equipment. General acid-resistant vitreous and porcelain enamels can meet 80~90% of market demands.

#### 01 JT-7#

Technical indicators	Measuring units	Testing standards	Reference targets	Testing data
				JT-7#
168-hour corrosion resistance to 20% boiling hydrochloric acids	g/m <sup>2</sup> .d	GB/T7989-2013	≤1.2	0.7-1.0
24-hour corrosion resistance to 0.1mol/L 80°C sodium hydroxides	g/m <sup>2</sup> .d	GB/T7991.1-2021	≤5.0	3.0-4.0
Resistance to abrupt temperature difference variations	°C	GB/T7987-2013	≥200	200-210
Mechanical shock resistance	J	GB/T7991.4-2019	≥220x10 <sup>-3</sup>	260-280
Color	Prussian blue			
Applicable to	Reactors & stirring accessories			

#### 02 JT-9901H#

Technical indicators	Measuring units	Testing standards	Reference targets	Testing data
				JT-9901H#
168-hour corrosion resistance to 20% boiling hydrochloric acids	g/m <sup>2</sup> .d	GB/T7989-2013	≤1.2	0.7-1.0
24-hour corrosion resistance to 0.1mol/L 80°C sodium hydroxides	g/m <sup>2</sup> .d	GB/T7991.1-2021	≤5.0	3.0-4.0
Resistance to abrupt temperature difference variations	°C	GB/T7987-2013	≥200	200-210
Mechanical shock resistance	J	GB/T7991.4-2019	≥220x10 <sup>-3</sup>	240-260
Color	Dark blue			
Applicable to	Reactors & stirring accessories			

#### 03 JT-4#

Technical indicators	Measuring units	Testing standards	Reference targets	Testing data
				JT-4#
168-hour corrosion resistance to 20% boiling hydrochloric acids	g/m <sup>2</sup> .d	GB/T7989-2013	≤1.2	0.7-1.0
24-hour corrosion resistance to 0.1mol/L 80°C sodium hydroxides	g/m <sup>2</sup> .d	GB/T7991.1-2021	≤5.0	3.0-4.0
Resistance to abrupt temperature difference variations	°C	GB/T7987-2013	≥200	200-210
Mechanical shock resistance	J	GB/T7991.4-2019	≥220x10 <sup>-3</sup>	270-300
Color	White			
Applicable to	Reactors & stirring accessories			

## ▶▶ Introduction Of High End Glaze Varieties

### 01 High-performance ceramic glass glaze

01 High abrasion resistance;  
02 Chemical and physical properties: Strong resistance to abrupt temperature difference changes, high resistance to mechanical shock, acid corrosion resistance  $\leq 0.8$ , and alkali corrosion resistance  $\leq 3.5$ .

### 02 Detachable groundcoat glaze for stirring

01 Superior adherence;  
02 High expansion coefficient;  
03 Suitable for double-sided enameling

### 03 Super-grade alkali resistant glaze

Alkali corrosion resistance  $\leq 1.0g/m^2.d$

### 04 Anti-phosphoric acid glaze

Resistant to corrosion by high-temperature phosphoric acid solution.

### 05 Special anti-static glaze

Realize electricity conductance at a static level.

### 06 Glaze for low-level dissolution of metallic ions

Realizing low-level dissolution of various ions and alkali metals, applicable to "raw materials for electronic materials", "high-purity reagents", "semi-conductor materials" and other fields.

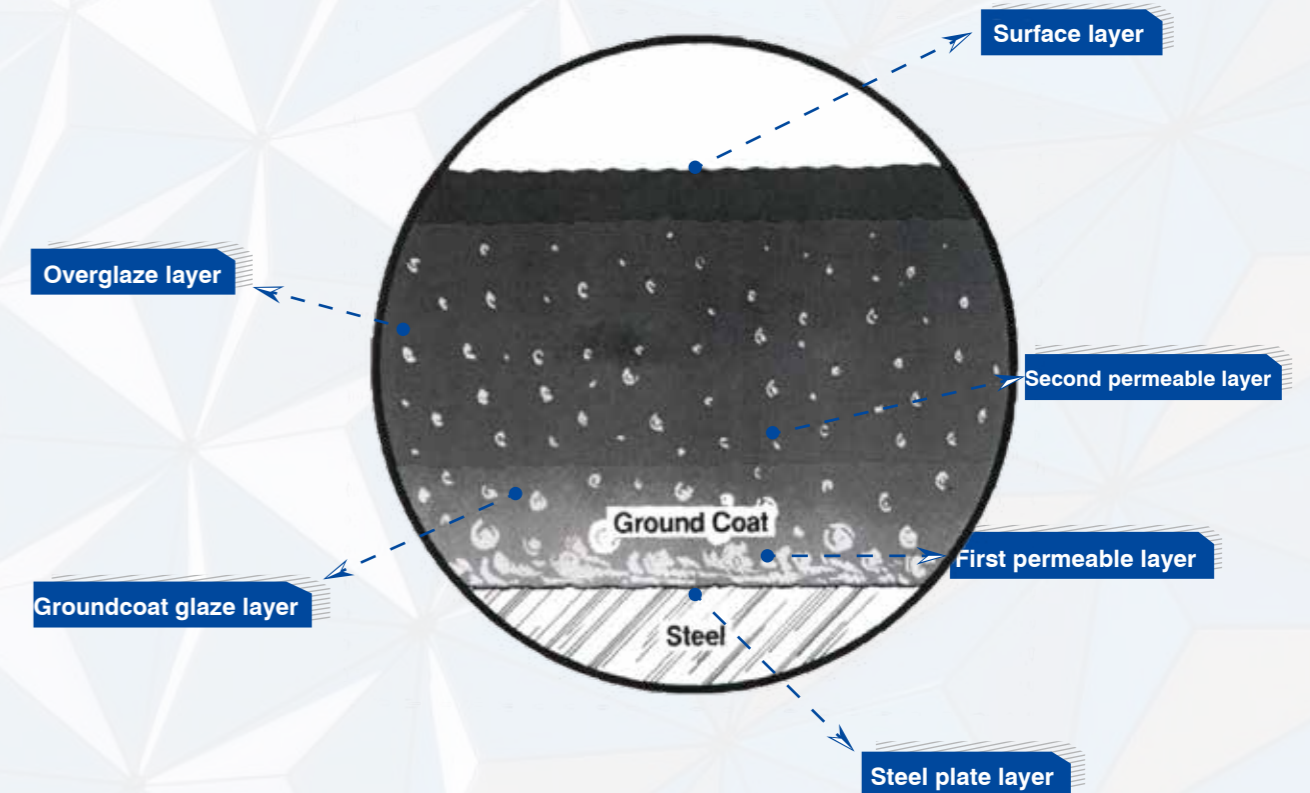

## ▶▶ Enamel And Enameling Process Combined

### Perfect Combination Of Glaze And Enamelling Process



**As known to all,** we cannot produce glass lined coatings (also known as the glass lined layers) through simple firing of vitreous and porcelain enamels. In this evolving process, materials in fact undergo a series of extremely complicated physicochemical reactions, as shown in the figure above. Because of such a permeability phenomenon, the original stratification of vitreous and porcelain enamels changes. Then, physicochemical properties of the glass lined layer also changed.

Although vitreous and porcelain enamels are not a terminal product, it plays a critical role in the manufacturing and applications of glass lined equipment. Sufficient exertion of properties of the vitreous and porcelain enamels depends on quality of the plates, iron forming processes, iron surface treatment, enameling, firing, firing furnaces, and the content of atmosphere and water vapor in the furnace. Glass lined parts have an extremely complex production process, and variables in each link may affect performance of the finished products.

**\*Recommendations! Enamel materials and optimal enameling process should be selected according to specific operating conditions and media required by different customers.**

## Analysis Of Factors Affecting The Service Life Of Reactor Equipment

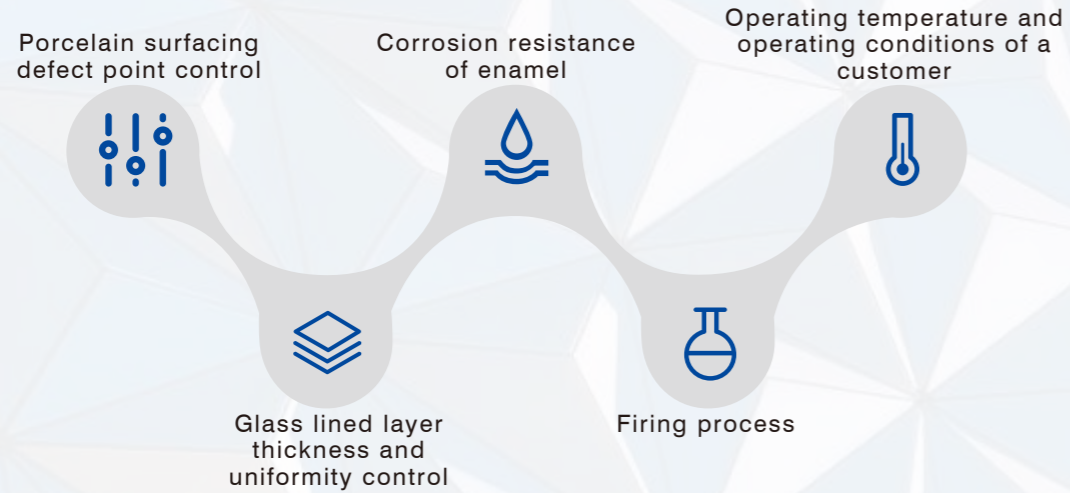

## Analysis Of Factors Affecting The Service Life Of Reactor Equipment

✓ Resistant to fish-scaling and high temperature, high corrosion resistance, and capable of extending the service life of equipment.

✓ Scientific formulation, a founding technique based on electric melting furnace, laminated glazes, and a fine process.

✓ Pass strict inspections, HG/T4798-2021, and ISO9001:2015 certification.

## ▶▶ Glass-Lined Glaze For Chemical Industry



▲ Double-sided Enamel Feeding Tube



▲ Glass lined stirring



▲ Reaction kettle



▲ Glass lined sight glass



▲ Glass lined straight tubes

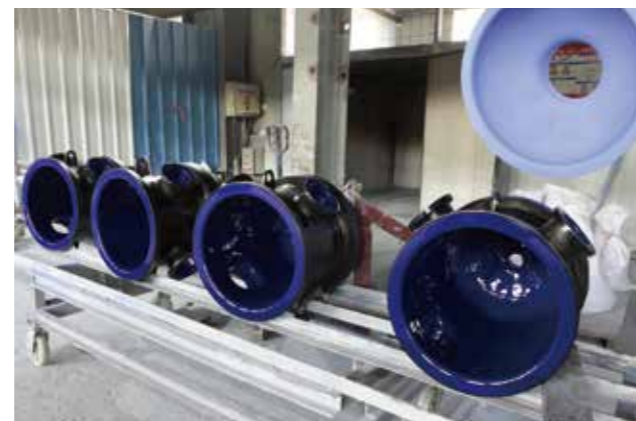

▲ Glass lined tower section tower cap

## 3 GLASS LINED EQUIPMENT PARTS

- » Glass Lined Pipe
- » Double-sided Enamel Feeding Tube
- » Glass Lined Porous Disc Condenser
- » Glass Lined Tower Section Tower Cap
- » Glass Lining Equipment Products



## ▶▶▶ New Product Development Project



### ☺01 Glass lined straight tubes

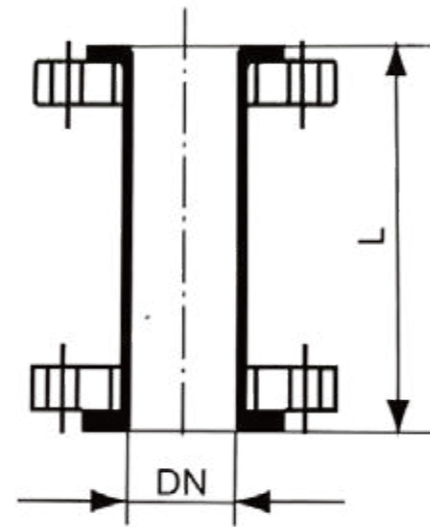

#### Product features:

- Produced in strict accordance with international standards
- High-quality glaze (in white, sky blue and cobalt blue) special for pipes
- Adopting processes of cold penetration and a multiple thin-layer method
- Provided with nozzle welding neck flanges, and automatic welding technique; and weld joints are distant from the flange opening



DN(mm)	25	32	40	50	65	80	100	125	150	200	250
L(mm)	100-1000			100-2000			100-3000				

### ☺02 Glass lined 90° elbows

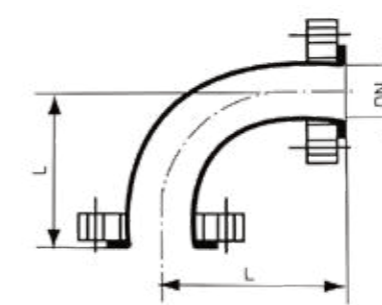

#### Product features:

- Produced in strict accordance with international standards
- High-quality glaze (in white, sky blue and cobalt blue) special for pipes
- Adopting processes of cold penetration and a multiple thin-layer method
- Provided with nozzle welding neck flanges, and automatic welding technique; and weld joints are distant from the flange opening

DN	25	32	40	50	65	80	100	125	150	200	250
L (mm)	95	105	110	125	135	145	155	175	200	260	310

### ☺03 Glass lined 45° elbows

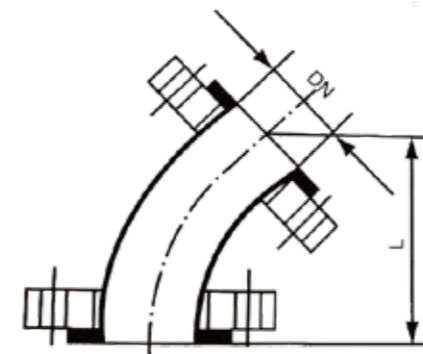

DN (mm)	25	32	40	50	65	80	100	125	150	200	250
L (mm)	110	120	125	140	140	150	190	215	230	250	280

## ▶▶ New Product Development Project

### ☑ 04 Glass lined cross joint

#### Product features:

- Produced in strict accordance with international standards
- High-quality glaze (in white, sky blue and cobalt blue) special for pipes
- Adopting processes of cold penetration and a multiple thin-layer method
- Provided with nozzle welding neck flanges, and automatic welding technique; and weld joints are distant from the flange opening

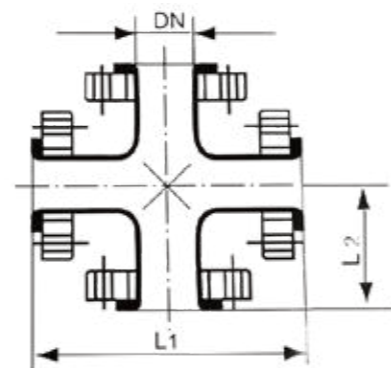

### ☑ 05 Glass lined T-joint with equal diameters

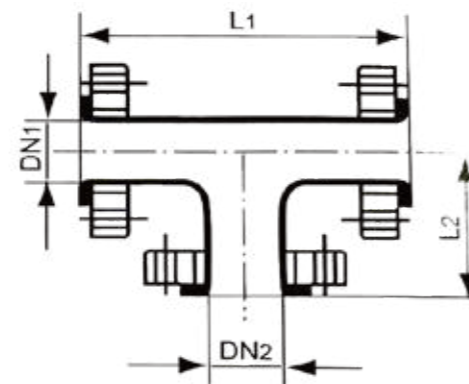

DN (mm)	25	32	40	50	65	80	100	125	150	200	250
L1	180	210	220	240	260	280	310	340	390	460	540
L2	90	105	110	120	130	140	155	170	195	230	270

## ▶▶ Double-sided Enamel Feeding Tube

### ☑ 01 Glass lined large-aperture feeding tubes

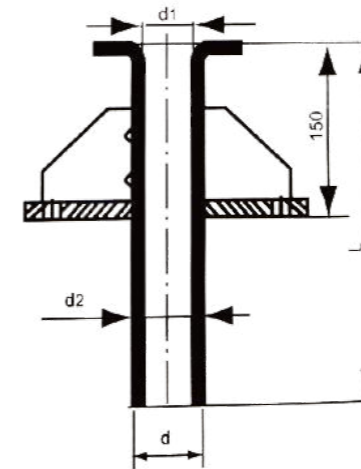

#### Product features:

- Produced in strict accordance with international standards
- High-quality glaze (in white, sky blue and cobalt blue) special for pipes
- Adopting processes of cold penetration and a multiple thin-layer method

\* Dimensionally customizable as required by users



DN (mm)	d	d1	d2	Lmax
50	80	40	63.5	1050
100	96	56	80	1750

## ▶▶ Glass Lined Porous Disc Condenser



Widely applied



Special glaze



Lightweight & compact



Easy for replacement



Uneasy to leak

### 01 New type glass lined porous disc condensers

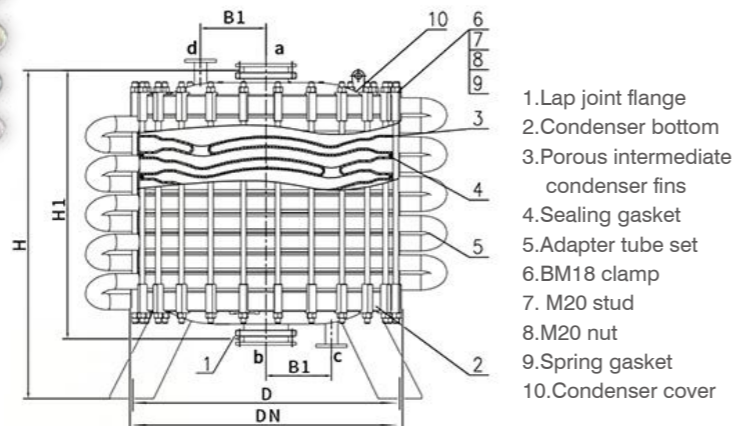

Items		In condenser	In interlayers
Pressure	Designed	FV~0.1Mpa	0.35Mpa
	Operating	-0.098~0.098Mpa	0.3Mpa
Temperature	Designed	0~200°C	
	Glass lined layer thickness		
Plate material		Q245R	
Nominal specifications of the outlets	Feed inlet		DN150 PN0.6
	Feed outlet		DN100 PN0.6
	Water inlet		PL32 PN1.0
	Water outlet		PL32 PN1.0
Nominal specifications of the outlets	Parts	Varieties	Features
	Gaskets	Metallic corrugated PTFE gaskets	A reliable sealing property & vacuum tolerable
		Ordinary PTFE asbestos gaskets	High sealing performance
	U-shaped tubes	304 stainless steel hose	Higher bar tolerance (operating pressure P≤0.3MPa)
		Rubber tubes	High-pressure resistant (operating pressure P≤0.2MPa)
Glaze type	Customized based on specific media	Superior in acid and alkaline erosion resista	

### Product features:

- Applicable to all chemical media excluding hydrofluoric acids, phosgene, strong phosphoric acids (concentration >30% & temperature >150°C), strong alkali (PH>12 & temperature >100°C) and other substances containing fluorine.
- With the cold spray process and a multiple thin-layer method, we are capable of fulfilling professional glaze customization according to specific operating conditions of reactions.
- Being small-sized, lightweight, and structurally simple and compact, it can complete heat transfer through counterflows of thermal and cold media.
- In case of damages of a single part after a certain period of service, users can change or reduce this part without causing complete machine scrapping or production suspension. Therefore, the service life of complete machine can be substantially extended.

#### New type disc condensers

With a three-pore design, fluids are distributed uniformly. Such new condensers are used in high vacuum distillers and evaporators.

#### Orifice

Because of a rather small single-pore outlet (intersecting by 180°), fluid resistance is high and the air cannot be distributed uniformly. Consequently, bias flows are generated. They cannot be used in a vacuum condition.

Thickness of condenser fins is reduced, while flow rate of cooling water improved, thus making it less likely for scale formation to occur. Compared with an ordinary condenser of an equal area, the total coefficient K of heat transfer is raised by about 30%.

#### Thickness

Although condenser fins are thick, flow rate of the cooling water is low, so that scale formation takes place easily. Besides, heat transfer efficiency of such ordinary condensers is also low.

Provided with metallic corrugated PTFE gaskets, their expansion and shrinkage rates are lowered and pressure resistance elevated, which makes it less likely for leakage to occur. Therefore, they are rather suitable for high vacuum sealing.

#### Gasket

Generally, 35mm gaskets with high expansion and shrinkage ratios are selected for use. They are not only vulnerable to deform, but also weak in pressure resistance, thus inapplicable to high vacuum conditions. Leakage occurs frequently.

## ▶▶ Glass Lined Tower Section Tower Cap

### Product features:

- Produced in strict accordance with international standards
- High-quality glaze (in white, sky blue and cobalt blue) special for pipes
- Adopting processes of cold spray and a multiple thin-layer method
- Provided with nozzle welding neck flange; and weld joints are distant from the flange opening



\*Dimensionally customizable as required by users

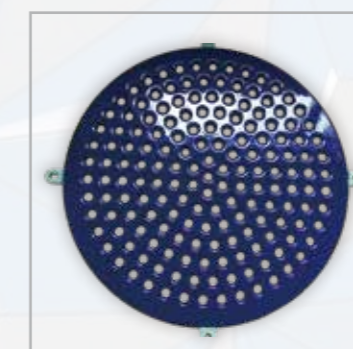

## ▶▶ Glass Lining Equipment Accessories

### ☺01 Glass lined reducing flange

### Product features:

- Produced in strict accordance with international standards
- High-quality glaze (in white, sky blue and cobalt blue) special for pipes
- Adopting processes of cold spray and a multiple thin-layer method
- Adopting processes of cold spray and a multiple thin-layer method

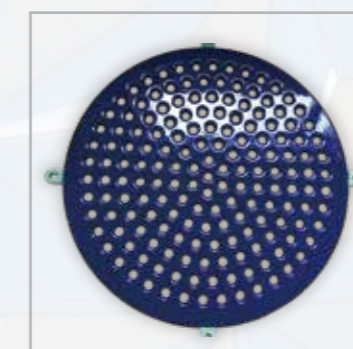
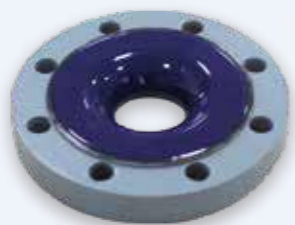

# 4 GWIPPO BUSINESS SCOPE



◎ **90%**  
Glass lined equipment manufacturers of China

◎ **Korea**    ◎ **Philippines**    ◎ **Southeast Asia**

Specialized in high-performance anti-corrosion vitreous and porcelain enamels, we have won trust from domestic customers, and our products are exported to overseas markets of Korea, Philippines, and Southeast Asia. GWIPPO wins the market with technologies, customers with whole-hearted services, and the reputation with integrity. Customer satisfaction is our unremitting pursuit.

